

# BUTTERFLY VALVES - 250 PSI

\*NSF372 • Lug Design • Ductile Iron Body • Extended Neck  
 Bi-Directional • Molded Seat • ISO Mounting Pad • Gear Operator  
**SIZE 2" - 8"**

STANDARDS: MSS SP-67 & API-609 Cat. A

END CONNECTION: ANSI CL 125/150 FLANGES

WALL THICKNESS: KITZ STD

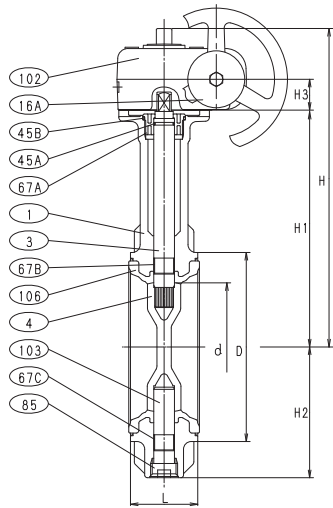

MATERIAL LIST		
NO.	NAME OF PART	SPECIFICATION
1	BODY	DUCTILE IRON (A536 Gr. 65-45-12)
3	STEM*	STAINLESS STEEL (A276, Type 410; AISI, Type 329)
4	DISC (1)	DUCTILE IRON, AL. BRONZE, AND 316 SS
16A/B	NAME PLATE	ALUMINUM
45A/B	O-RING	NBR/EPDM
67A	BEARING	POLYACETAL
67B/C	STEM BEARING	G/F PTFE (2" - 5") METAL BACKED PTFE (6", 8")
85	PLUG	ZINC DIE-CAST (2)
99A	SET BOLTS	CARBON STEEL
102	GEAR UNIT	ALUMINUM DIE-CAST (B85, SC102A)
103	BOTTOM STEM	STAINLESS STEEL (A276, TYPE 410; AISI, Type 329)
106	SEAT RUBBER (3)	NBR/EPDM
145	SPRING WASHER	CARBON STEEL

(1) Line scribed on top of the stem indicates the disc position

(2) Chromate Coating

(3) Vulcanized to the Body



**Code # 6113 (B/E) G**  
 Disc: Ductile Iron  
 (A536 + ENP)

**Code # 6123 (B/E) G**  
 Disc: Aluminum Bronze\*  
 (C95400)

**Code # 6133 (B/E) G**  
 Disc: 316 SS\*  
 (A351 Gr. CF8M)

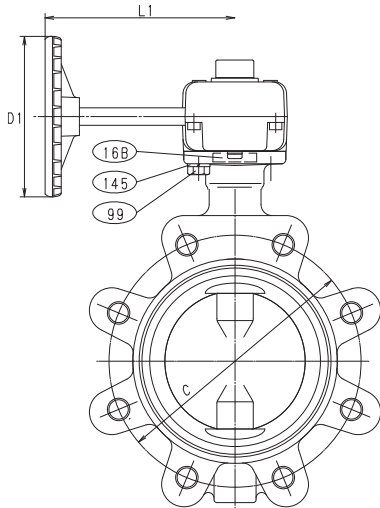

DIMENSIONS											
SIZE	d	D	C	H	H1	H2	L	D1	L1	Wafer	Lug
										Lbs	Lbs
										Kgs	Kgs
in. 2	1.97	3.54	4.75	7.64	5.79	2.64	1.69	3.15	4.78	4.9	7.1
mm 50	50	90	120.5	194	147	67	42.9	80	121.5	2.2	3.2
in. 2 1/2	2.56	4.09	5.50	7.95	6.10	2.95	1.81	3.15	4.78	5.7	8.4
mm 65	65	104	139.5	202	155	75	46	80	121.5	2.6	3.8
in. 3	3.15	4.88	6.00	9.29	6.81	3.58	1.81	4.33	5.31	8.6	13.0
mm 80	80	124	152.5	236	173	91	46	110	135	3.9	5.8
in. 4	3.94	5.75	7.50	9.69	7.20	3.98	2.06	4.33	5.31	9.2	19.0
mm 100	100	146	190.5	246	183	101	52.3	110	135	4.2	8.8
in. 5	4.92	6.93	8.50	10.79	8.31	5.00	2.19	4.33	5.91	14.0	26.0
mm 125	125	176	216	274	211	127	55.6	110	150	6.3	12.0
in. 6	5.91	8.11	9.50	11.26	8.78	5.47	2.19	4.33	5.91	19.0	32.0
mm 150	150	206	241.5	286	223	139	55.6	110	150	8.5	15.0
in. 8	7.76	10.12	11.75	12.80	9.76	6.65	2.38	6.69	7.09	30.0	49.0
mm 200	197	257	298.5	325	248	169	60.5	170	180	13.0	22.0

For gear operator details, refer to page 24.

**NOTE:**

KITZ lug style butterfly valves are rated for bi-directional dead end service to full working pressure of the valve with the downstream flange removed. In dead end service exceeding 96 hours, a downstream flange is recommended.



\*Butterfly valves with AlBrz or SS disc conform with lead content requirements for "lead free" plumbing as defined by California, Vermont, Maryland, and Louisiana state laws and the U.S. Safe Drinking Water Act. These products further conform with the requirements of NSF/ANSI Standard 372.